

### DESCRIZIONE / DESCRIPTION

Valvola a cartuccia regolatrice di portata compensata 3 vie normalmente chiusa.  
Può essere impiegata come regolatore di portata prioritario compensato con bypass.  
3 way flow control valve pressure compensated normally closed. It can be used as a priority-type flow regulator with pressure-compensated, regulated and bypass flow.

### TIPO / TYPE

**V3Q**

### SIMBOLO / SYMBOL

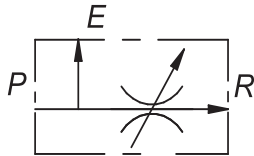

### SPECIFICHE / SPECIFICATION

Cavità Cavity	C 332 - 3
Pressione max. Max. Op. pressure	350 bar
Portata max. in ingresso (1) Max inlet Flow (1)	120 l/min
Portata max. regolata (3) Max regulated Flow (3)	70 l/min

### DIMENSIONI / DIMENSIONS

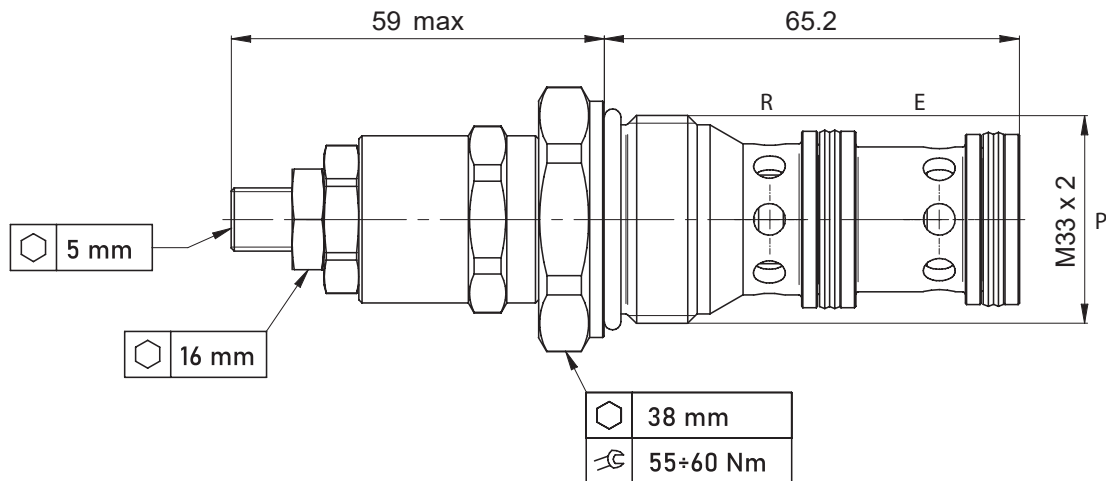

### INFORMAZIONI PER L'ORDINE / ORDERING INFORMATION

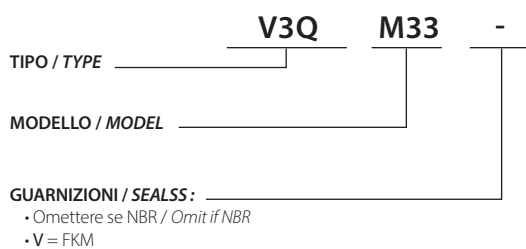

#### REGOLAZIONI / ADJUSTMENTS:

- 1 = Vite / Hex. Socket screw
- 2 = Volantino / Handknob
- 3 = Piombatura / Anti-tamper cap

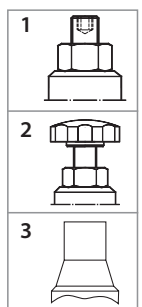

### GRANDEZZA / SIZE

**M33**

### PRESTAZIONI / PERFORMANCE

