



**PATENT  
PENDING**

## NEW HYDRAULIC TRAILER BRAKE VALVE

According to new EU regulation for agricultural and forestry vehicles (RVBR)

**"S5"  
VERSION**

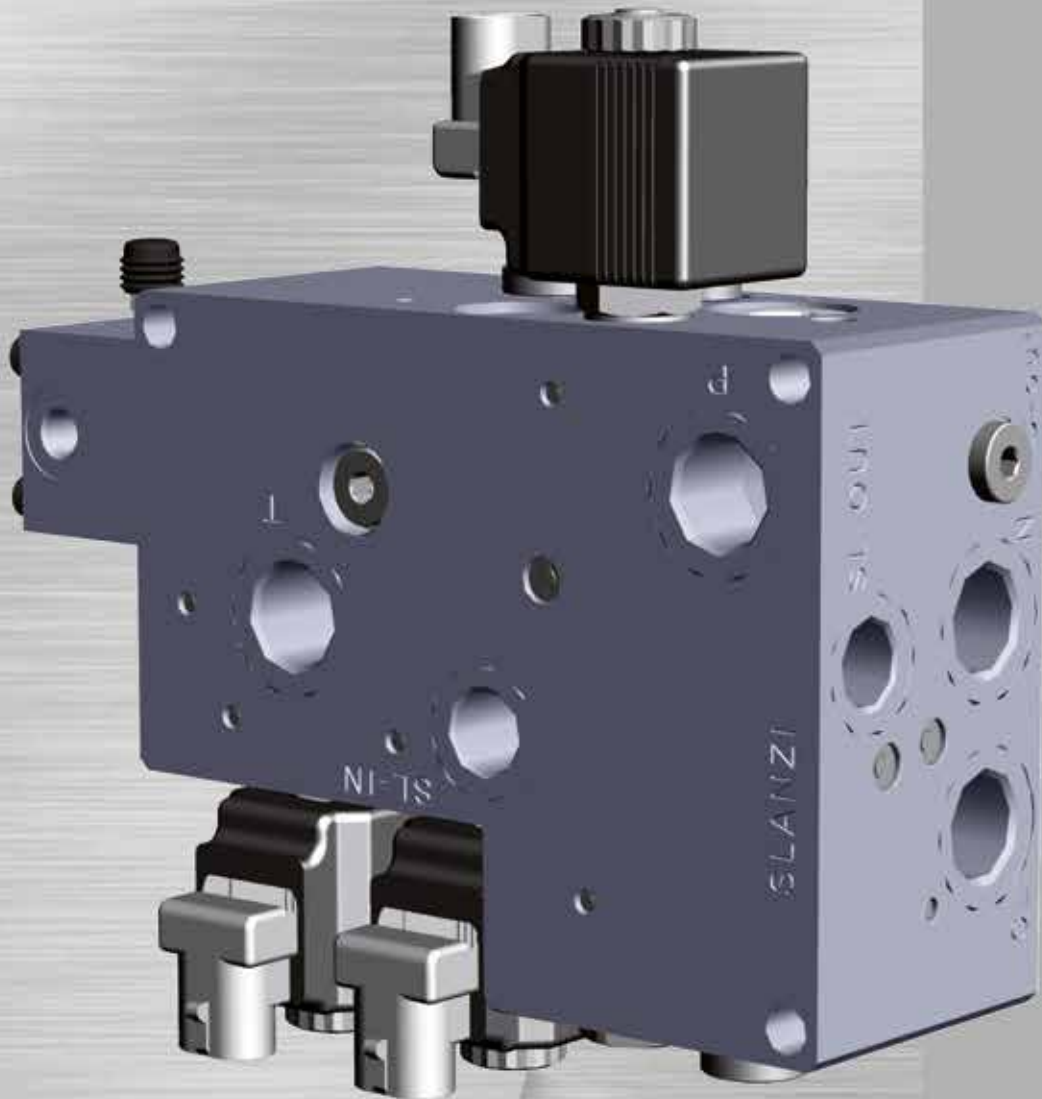

**GOOD BRAKES MAKE YOU TO GO FASTER!**



# SLANZI HYDRAULIC TRAILER BRAKE VALVE

According to new EU regulation for agricultural and forestry vehicles (RVBR)

## APPLICATION

**PATENT  
PENDING**

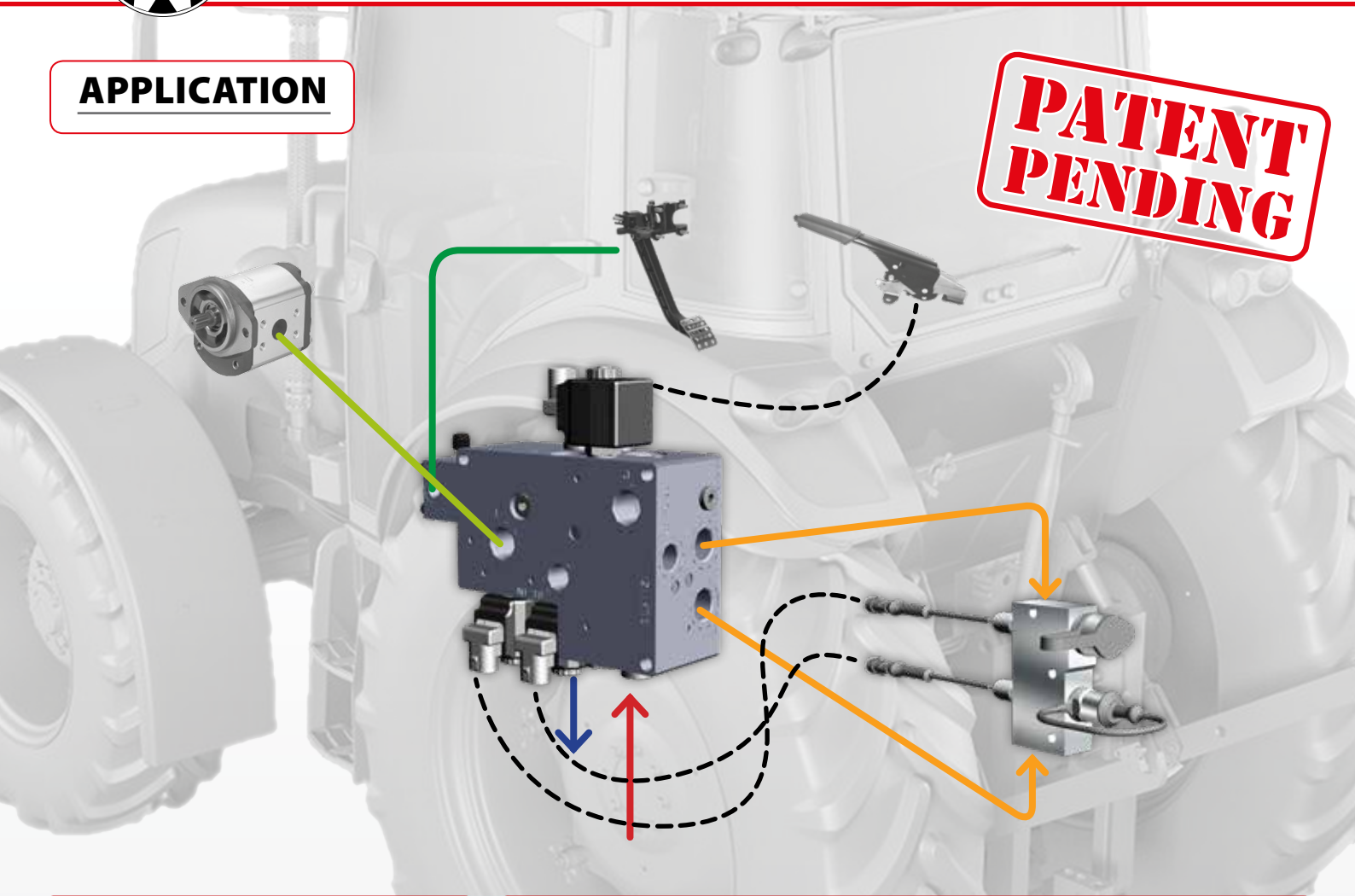

## MAIN FEATURES

- Automatic zeroing of the secondary line in case of rupture or loss in the control line.
- Space optimization and compact design.
- Automatic valve cut-off in case of disconnected control line.
- System capable to automatically recognize the type of connected trailer (single or double line) and to self-adjust the braking performances (available in the version with integrated couplings).
- Valve available for open or LS circuit.
- Valve version compatible with CUNA regulation available.

## CUNA VERSION

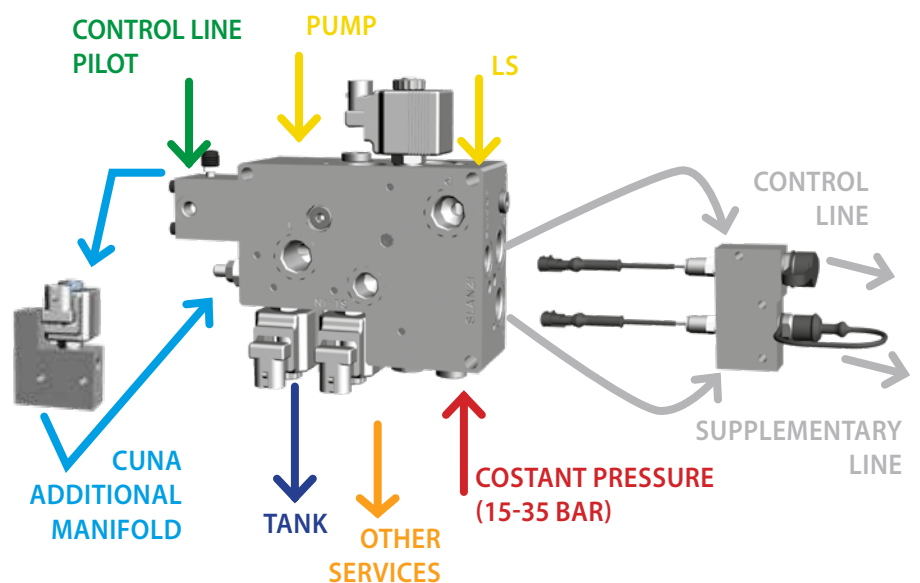

SLANZI OLEODINAMICA s.r.l.

Via Provinciale Nord, 221 - 42017 NOVELLARA (RE)  
Tel. 0522/651313 - 651298 - Fax 0522-756001 - E-mail: info@slanzi.it

[www.slanzi.it](http://www.slanzi.it)