

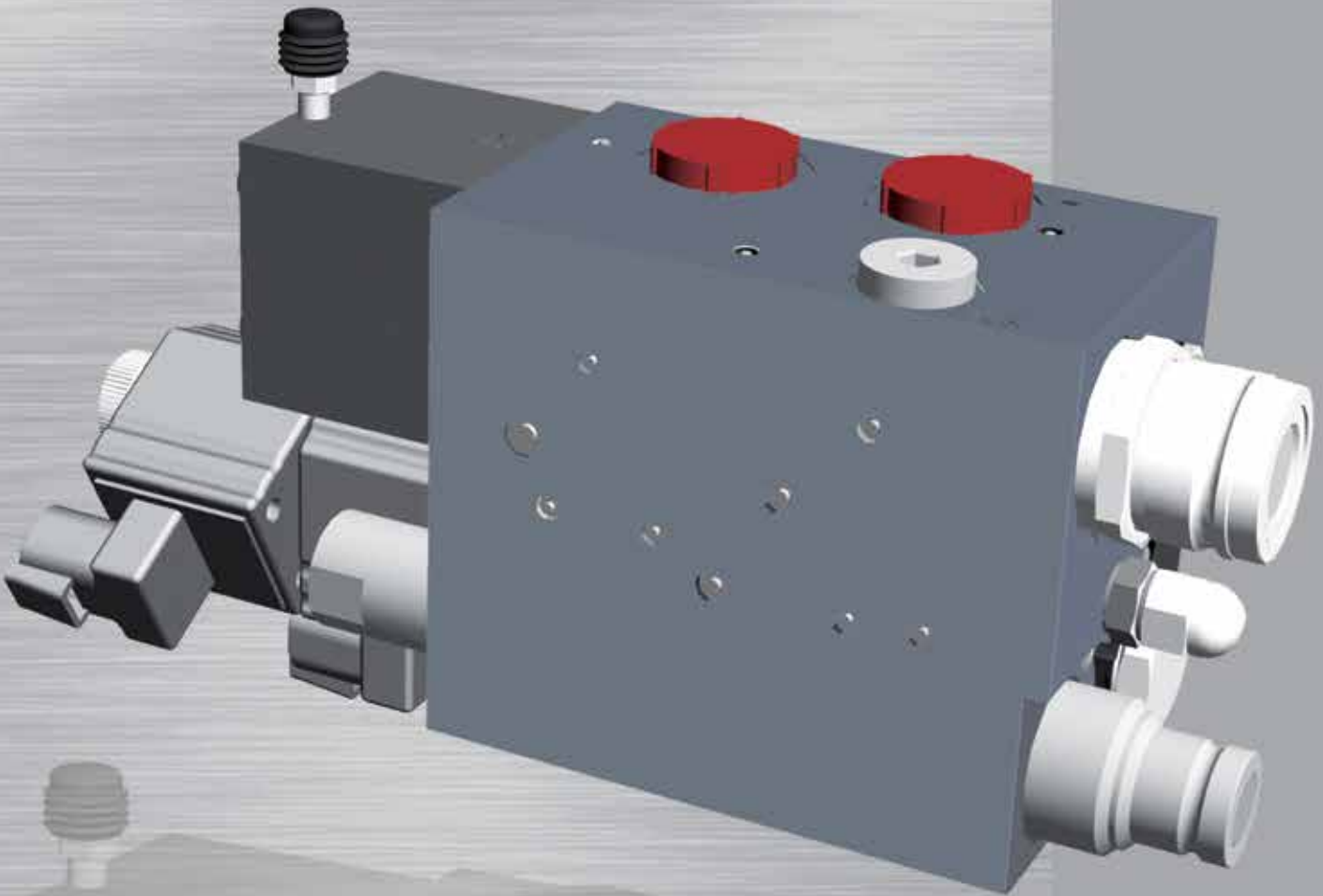

**PATENT  
PENDING**

## NEW HYDRAULIC TRAILER BRAKE VALVE

According to new EU regulation for agricultural  
and forestry vehicles



***GOOD BRAKES MAKE YOU TO GO FASTER!***



# SLANZI HYDRAULIC TRAILER BRAKE VALVE

According to new EU regulation for agricultural and forestry vehicles

## APPLICATION

**PATENT  
PENDING**

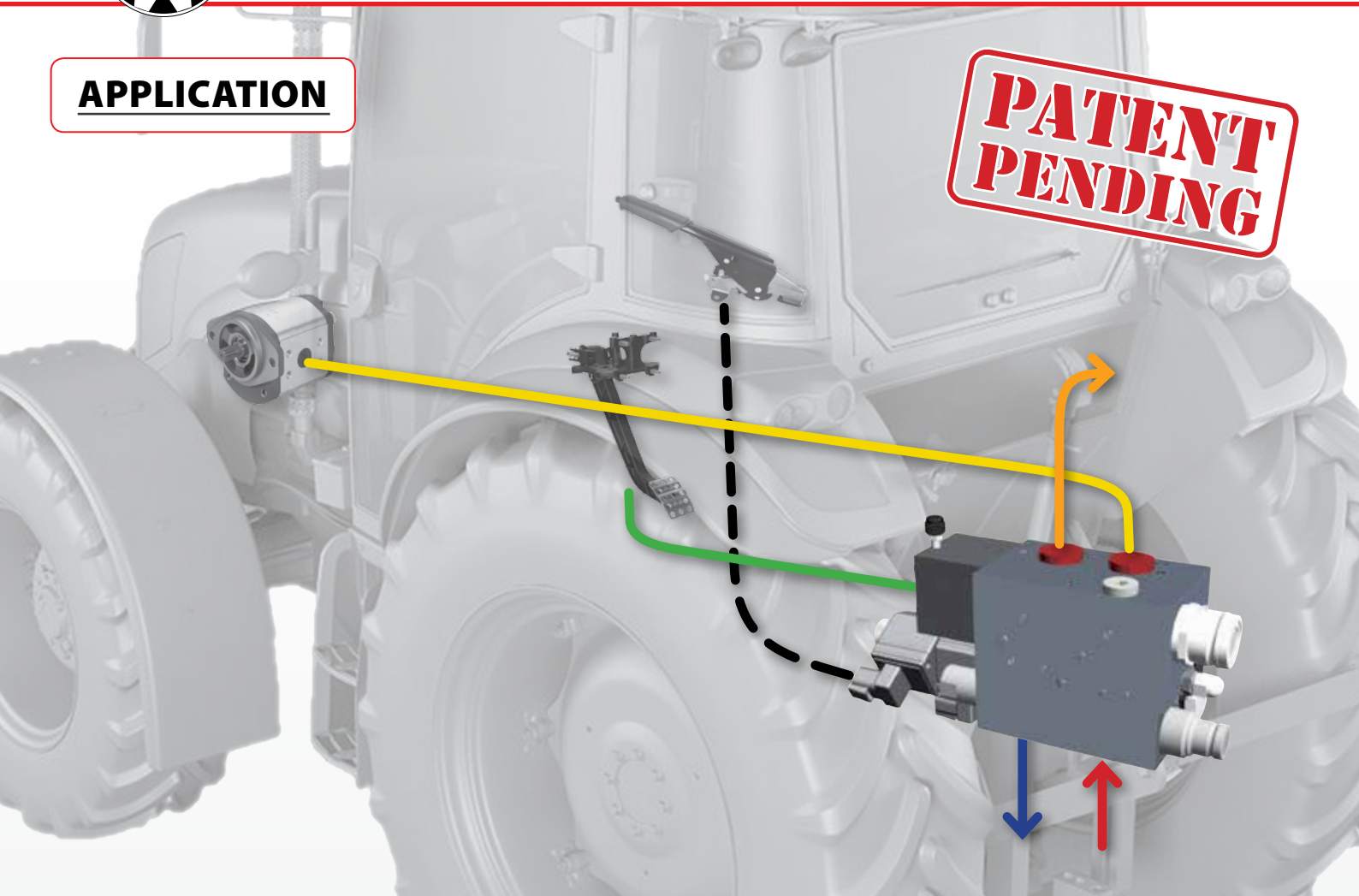

## MAIN FEATURES

- Automatic zeroing of the secondary line in case of rupture or loss in the control line.
- Space optimization and compact design.
- Automatic valve cut-off in case of disconnected control line.
- System capable to automatically recognize the type of connected trailer (single or double line) and to self-adjust the braking performances (available in the version with integrated couplings).
- Available valve version with remoted couplings.
- Valve available for open or LS circuit.
- Safety system: in case of malfunction of electronic control transmission, not apply the brake contrary to the driver's intention.

## CONNECTIONS

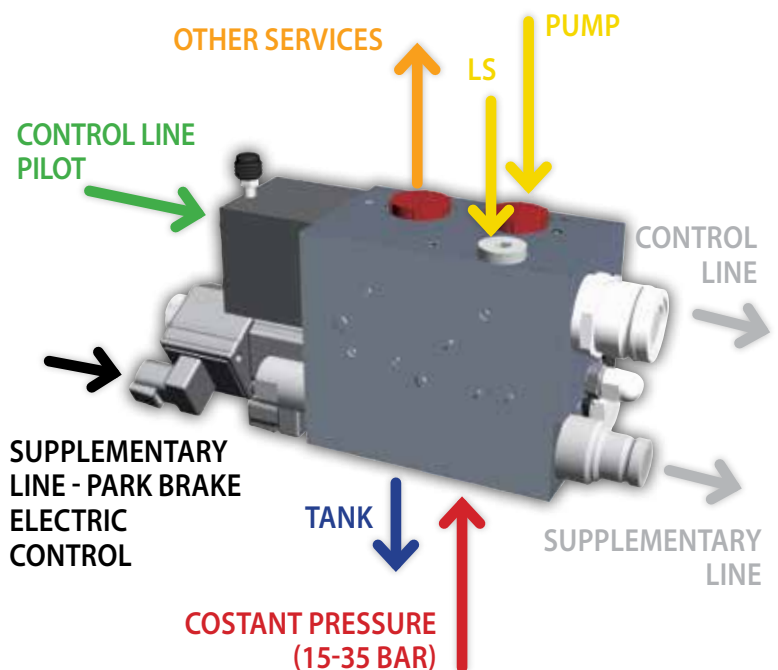

SLANZI OLEODINAMICA s.r.l.

Via Provinciale Nord, 221 - 42017 NOVELLARA (RE)

Tel. 0522/651313 - 651298 - Fax 0522-756001 - E-mail: info@slanzi.it

[www.slanzi.it](http://www.slanzi.it)